



### Specifications: CM800i

Tile bridge included

System Type	8" Coax, in-ceiling, ported (64 Watt transformer for 25/70.7/100 Volt or voice coil/8 Ohm direct)
Frequency Response (-3 dB) <sup>1</sup>	85 Hz - 22 kHz
Low Frequency (-10 dB) <sup>1</sup>	60 Hz - 22 kHz
Max. Program Power	250 Watts
Max. Continuous Power RMS <sup>2</sup>	125 Watts
Max. SPL dB @ 1 M RMS	114.5 dB
Sensitivity dB @ 1W/1M <sup>3</sup>	93.5 dB
Impedance (nominal)	8 Ohm (nominal value)
Coverage Angle (-6 dB @ 2 kHz)	100°
Coverage Angle (-6 dB @ 10 kHz)	100°
Directivity Factor (Q)	5.00 (Averaged 100 Hz - 10 kHz); 8.05 @ 2 kHz
Directivity Index (DI)	6.08 dB (Averaged 100 Hz - 10 kHz); 9.06 dB @ 2 kHz
Tap Selector	6-Position rotary switch with voice coil/8 Ohm direct

#### Transformer Taps

70.7 V	Output	100 V	Output	25 V	Output
64 W	111.5 dB	64 W	111.5 dB	4 W	99.5 dB
32 W	108.5 dB	32 W	108.5 dB	2 W	96.5 dB
16 W	105.5 dB	16 W	105.5 dB	1 W	93.5 dB
8 W	102.5 dB	8 W	102.5 dB	.5 W	90.5 dB
4 W	99.5 dB				

Transducer	
Low Frequency Driver	1 x 203 mm (8.0 in) Polypropylene cone, butyl rubber surround
High Frequency Driver	25 mm (1.0 in) Convex aluminum tweeter with waveguide
Low Frequency Voice Coil	30.4 mm (1.2 in)
Crossover Frequency	3 kHz
Network Type	
Low Pass	12 dB per octave, 2nd order
High Pass	12 dB per octave, 2nd order
Enclosure Material	Drawn aluminum backcan with ABS baffle
Motor Board	Cast aluminum
Grille	Iridite-plated steel with powder-coat finish
Inputs	4 Pin, 5 mm Euroblock for individual or daisy chain connection
Colors	Black or white
Backcan Diameter	296.7 mm / 11.68 in
Backcan Height	201.7 mm / 7.94 in
Visible Diameter	27.5 mm / 1.08 in
Visible Height	375.0 mm / 14.76 in
Weight	5.7 kG / 12.5 lbs
Shipping Weight	17.7 kG / 39 lbs (2 per box, includes tile bridges)
Accessories	
Included	Tile bridge, Euroblock connector & installation aid
Optional	Pre-Construction Bracket (AC-CM8-PCB), Junction Box (AC-CM-JBOX) & architectural Square Grille (AC-CM8-SG)
Packaging	2 Per box

<sup>1</sup> Frequency response is measured in half space and includes a low-frequency peak > + 3 dB.

<sup>2</sup> Continuous power rating, EIA-426-B test.

<sup>3</sup> 2.83 Volts at a distance of 1 meter.

SoundTube continually develops new product innovations and improvements. Updates to existing products without prior notice are an example of SoundTube's drive for constant improvement.

### Key Features

- BroadBeam11<sup>®</sup> waveguide technology delivers a consistent BroadBeam<sup>™</sup> dispersion pattern for maximum coverage area per speaker (up to 10 kHz, EASE<sup>™</sup> documented).
- One 203 mm (8.0 in) polypropylene woofer and one 25 mm (1.0 in) convex aluminum tweeter with FerroFluid<sup>™</sup> cooling mounted to a proprietary cast-aluminum M8<sup>™</sup> baffle and heat sink.
- Rapid-installation blind-mount, fixed-wing mounting mechanism with constant-tension design affixing to ceiling thickness tolerances ranging from 6.4 mm (0.25 in) to 42.9 mm (1.69 in).
- Separate tool-free magnetic grille & bezel assembly for ease of install & in-field painting.
- Iridite-plated steel grille with protective powder-coated finish for lasting durability.
- Easy access 6-position selectable tap switch for 25, 70.7 and 100 Volt applications with voice coil/8 Ohm direct simplifies ordering & inventory tracking.
- 93.5 dB average sensitivity offers high-output capabilities & reduced amplification costs.
- UL 1480 & 2043, CE (EMC Directive 89/366/EEC, EN55020, EN55013), Mil-spec 810 & IEC529 approval pending.
- Included accessories: Tile bridge, Euroblock connector & paint mask.
- Optional accessories: Pre-Construction Bracket, Junction Box and Square Grille for architectural specifications.
- High-quality black or white paint finish. Custom paint colors optional.

### Description

The CM800i is an 8" 2-way blind-mount in-ceiling speaker design that delivers extended low-end response (60 Hz) and optimal off-axis performance (up to 10 kHz, EASE<sup>™</sup> documented). SoundTube's proprietary BroadBeam11<sup>®</sup> waveguide tweeter system delivers consistent high-performance audio across the operating bandwidth. The CM800i speaker design incorporates a low-profile grille, proprietary M8<sup>™</sup> motor-board and 6-position tap switch with voice coil/8 Ohm direct. Mounting hardware is included & features a fast & secure constant tension fixed-wing mounting system.



### Frequency Response

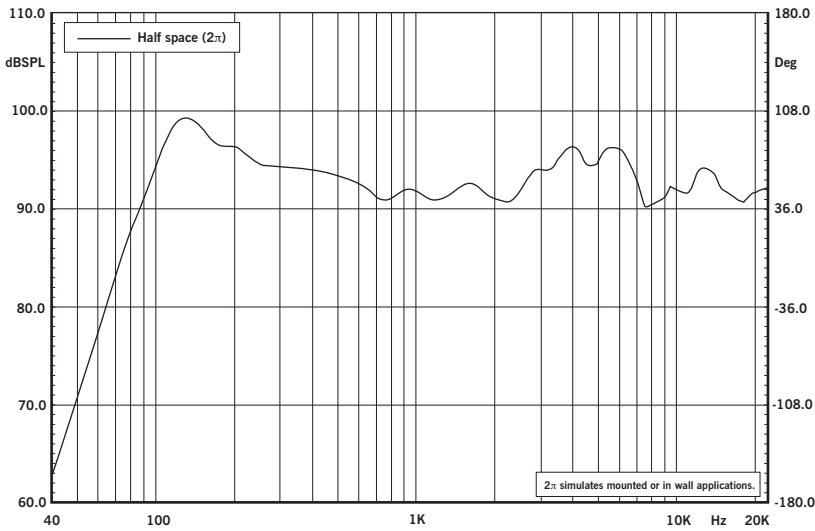

### Phase/Impedance Reponse

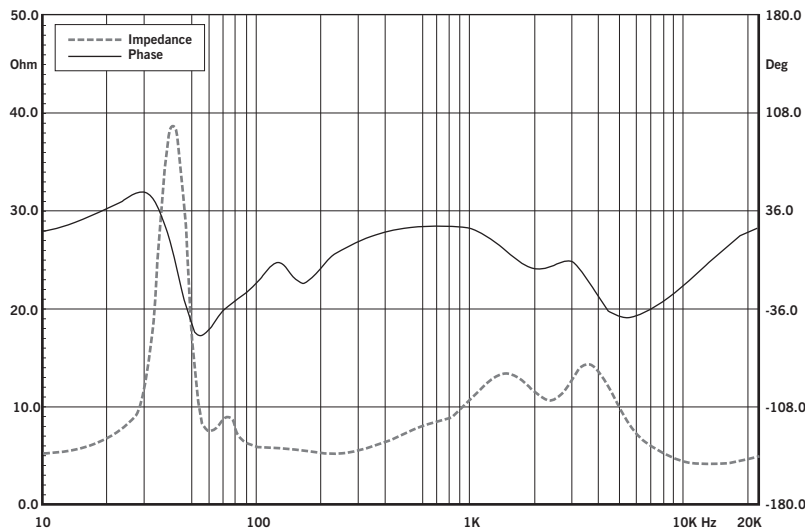

### Beamwidth (-6dB)

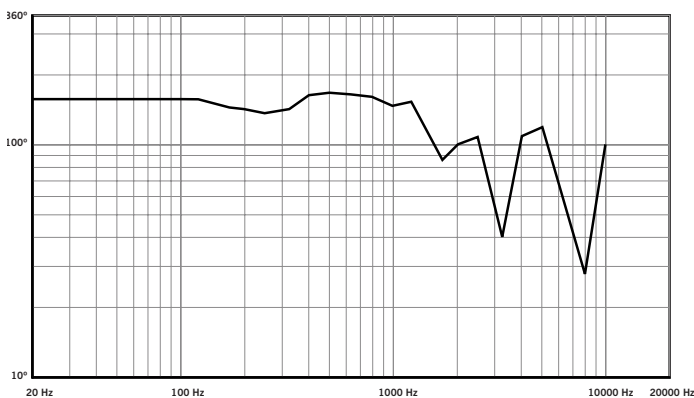

### Directivity Index (DI)

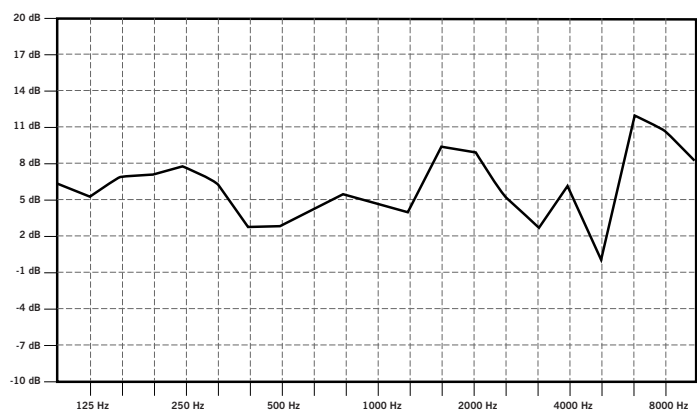

### Applications

Designed for in-ceiling background to foreground SPL applications, the CM800i delivers a broad dispersion pattern (1 kHz – 10 kHz, EASE™ documented), true low-end response (60 Hz, -10 dB) and high sensitivity (93.5 dB 1W/1M). The CM800i is ideal for nightclubs, bars, fitness centers, hotel, airports, convention centers, casinos, corporate venues, churches and other in-ceiling applications requiring background to foreground SPL. For applications where additional bass is required, SoundTube's CM801i 8" subwoofer provides low-end response down to 43 Hz.

### BroadBeam11® Wide Dispersion Technology

More than 3 years in development, SoundTube's proprietary BroadBeam11® technology incorporates a high-frequency waveguide mated to a 1" convex aluminum tweeter. The BroadBeam11® high-frequency waveguide delivers a consistent dispersion pattern across the upper registers of the frequency spectrum (up to 10 kHz, EASE™ documented). The result is an audio system with fewer speakers, reduced power needs, shorter installation time and cost savings on shipping & labor.



### Patented SoundTube Technologies

SoundTube Entertainment is constantly developing new technologies that enhance audio product performance. SoundTube Entertainment innovations are protected by multiple U.S. & international patents, which explicitly cover SoundTube dome, enclosure and dispersion technologies. SoundTube Entertainment actively defends its patents in order to protect SoundTube resellers and end users.

### Technical Data and Specification Tools

#### Technical Data

SoundTube Entertainment strives to provide complete and effective technical information and data to dealers, engineers and designers. All data are available from SoundTube Entertainment or at [www.soundtube.com](http://www.soundtube.com)

#### Data Acquisition

All performance data acquired at SoundTube's Technical Measurement Center (TMC) are analyzed using a variety of standard measurement techniques, including Measured Length

Sequence (MLS) and Time Delay Spectrometry (TDS). Performance, development and data acquisition tools include: Gold Line TEF 20, CLIO, LMS, LEAP, and proprietary modeling software. EASE™ data are acquired through an automated TEF 20/Outline/EASE™ interface.

**EASE™ Data** – 3-D polar plots.

**SoundTubeSPEC™** – Proprietary SoundTube speaker placement software.

### Architectural Specifications

The loudspeaker shall consist of a 203 mm (8.0 in) low-frequency transducer and a 25 mm (1.0 in) high-frequency transducer with a crossover network installed in the ported enclosure. The low-frequency voice coil diameter shall be 30.4 mm (1.2 in).

Performance specifications of a typical production unit shall be as follows: Usable frequency response shall extend from 60 Hz – 22 kHz (-10 dB, half space, no external equalization). Measured sensitivity (2.83 Volt input, 1 meter) shall be at least 93.5 dB. The speaker shall have a nominal impedance of 8 Ohms and be available for 25, 70.7 & 100 Volt modes

with voice coil/8 Ohm direct. The frequency-dividing network shall have a crossover frequency of 3 kHz with slopes of 12 dB per octave (2nd order) for both low & high pass filters. Rated power capacity shall be at least 125 Watts continuous power (RMS) and conform to EIA-426-B testing. Maximum continuous output at 1 meter shall be 114.5 dB.

Installation for the CM800i shall be by 2-screw blind-mount, constant tension winged assembly and shall attach to ceiling thickness tolerances ranging from 6.4 mm (0.25 in) to 42.9 mm (1.69 in). The fixed wing assembly shall be constructed of glass filled ABS material. The external wiring input connector shall be a 4-pin, 5 mm Euroblock for 8 Ohm or distributed systems and shall accept from 10 – 22 gauge wire.

The maximum backcan dimensions shall be no more than 201.7 mm (7.94 in) in height by 296.7 mm (11.68 in) in diameter. The maximum visible dimensions shall be no more than 27.5 mm (1.08 in) in height by 375 mm (14.76 in) in diameter. The backcan shall be constructed of aluminum.

The system shall include a 16-gauge galvanized steel support backing plate

### Polar Plots

125 Hz

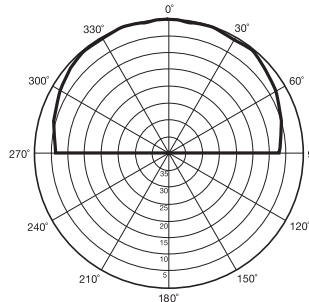

250 Hz

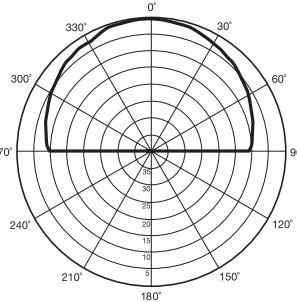

500 Hz

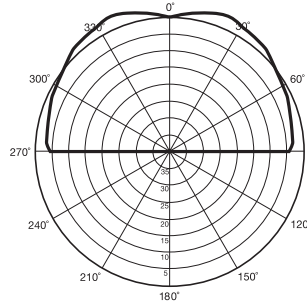

1000 Hz

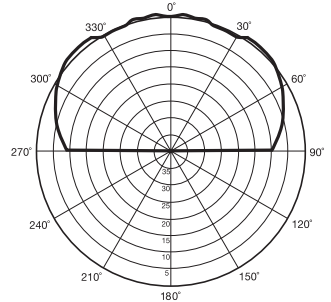

2000 Hz

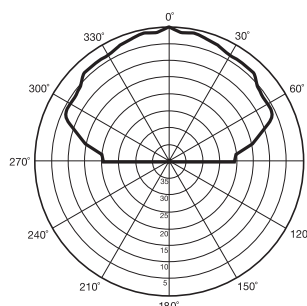

4000 Hz

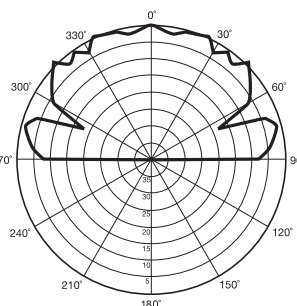

8000 Hz

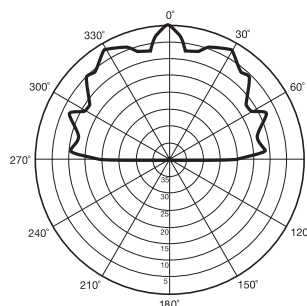

10000 Hz

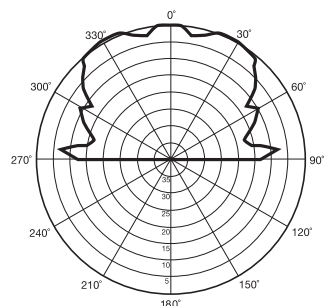

**Mechanical Drawings**

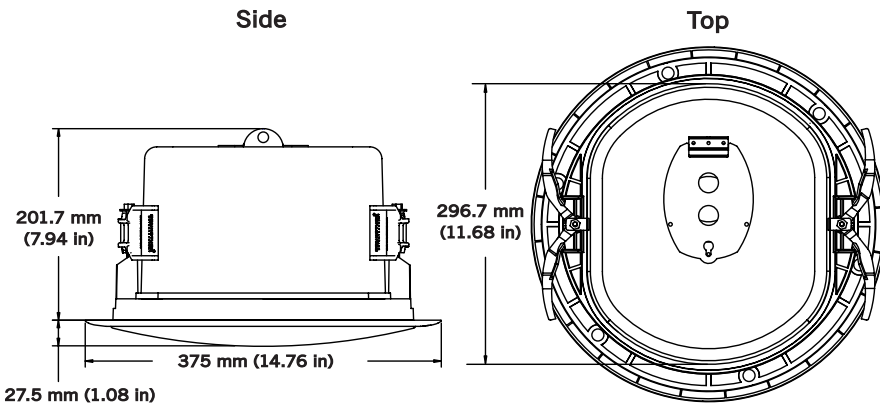

(tile bridge) to reinforce the ceiling material and tile support rails. The maximum tile bridge dimensions shall be no more than 600.1 mm (23.62 in) in length by 428.2 mm (16.86 in) in width and 10.4 mm (0.41 in) in thickness with 325.1 mm (12.80 in) cutout for speaker mounting.

The grille shall be constructed of iridite-plated, powder-coated steel with an ABS baffle for lasting performance. The affixed grille and bezel shall be mounted to the speaker enclosure (backcan) via magnetic strip and include safety wire. Also included are a paint mask for in-field painting and an installation aid that serves as a handhold during mounting.

The CM800i has an optional Pre-Construction Bracket (AC-CM8-PCB) that shall be compatible with an optional Junction Box (AC-CM-JBOX). An 18-gauge wire whip and Euroblock connector shall be included with the Junction Box. The maximum dimensions of the Pre-Construction Bracket shall be no more than 635 mm (25.0 in) in length by 457.2mm (18.0 in) in width and 127 mm (5.0 in) in thickness with a 326.1 mm (12.85 in) cutout for speaker mounting.

The CM800i will also have an optional Square Grille (AC-CM8-SG) for architectural applications.

The system shall be the SoundTube CM800i for both low & high impedance applications.

**Included Accessories**

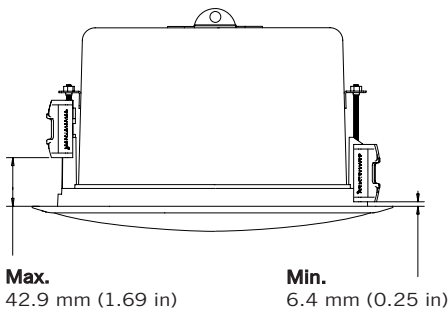

**Fixed Wing Mounting System**

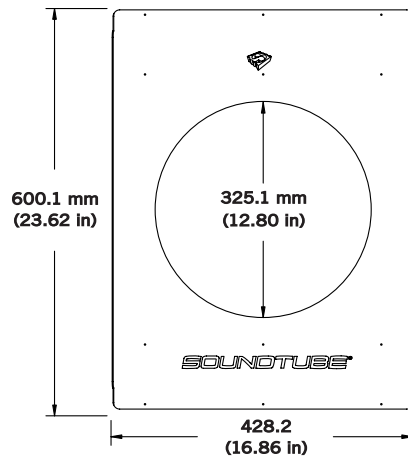

**Tile Bridge**

**SoundTube Entertainment**

6430 North Business Park Loop  
 Park City, Utah 84098  
 Phone 435.647.9555  
 Fax 435.647.9666  
 Toll Free 800.647.TUBE  
 www.soundtube.com

**All SoundTube products come with a 5-year limited warranty.**

**Paint Mask**

**Optional Accesories** (not shown)

- Pre-Construction Bracket (AC-CM8-PCB)
- Square Grille (AC-CM8-SG)
- Junction Box (AC-CM-JBOX)